

Levante Side Wind Instructions

Sep	Pcs	Component description
A	1	Rotation mechanism
B	2	Bamboo locking screws
C	4	M8 Bolts for Rotation
D	3	Assembly tools
E	1	Base Metal Sleeve
F	1	Elbow bracket
G	1	Hanging bracket
H	1	Cleat for tilt rope
I	1	Winch and handle
J	1	Wire cover tube
K	1	Bamboo rope pull
L	1	Upright pole
M	1	Cross pole
N	1	Parasol canopy
O	2	Base weights
P	1	Base frame
Q	8	Rotation cover
R	4	Long bolt and nut set
S	8	Feet for base frame
T	1	Locking arm
	2	Bamboo tightening bolts
	2	Plastic washers
U	1	Instructions
V	1	Canopy frame bolt and grey step washers

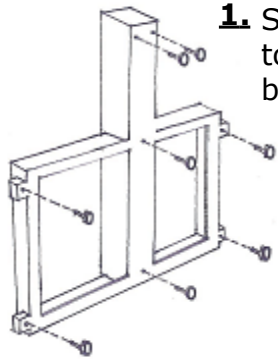

LEVANTE SIDE WIND INSTUCTIONS.



1. Screw the plastic feet (S) to the underside of the base frame (P).

2. Put the base frame in the desired (final) position, and adjust the feet until the frame is flat and level, before placing the base weights

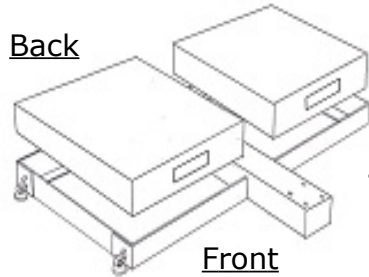

The next step will require 2 people, because of the weight of the bases.

3. Place the base weights (O) in the base frame (P). The cutout handles must go from front to back.

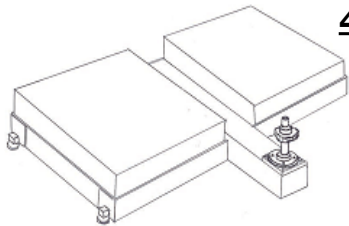

4. Fix rotation mechanism (A) to the base using the M10 bolts (C).

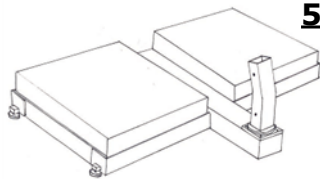

5. Place the metal sleeve (E) over the rotation mechanism (A) with the square (open) end upwards. Line up the corners of the sleeve with the locators on the round plastic base plate. The four dome nipples must sit inside each corner.

6. Fix the cleat (H) to the back of the upright pole (L) using 2 screws (Q). The looped part goes to the angled end of the post (top).

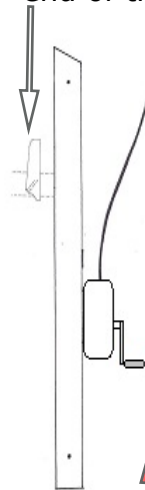

Steps **6.** and **7.** require a PH-2 screwdriver. (Not supplied)

7. Instructions for attaching the winch are on page 2.

8. Bolt the metal elbow (F) to the top of post (L) **Make sure the pulley points upwards.**

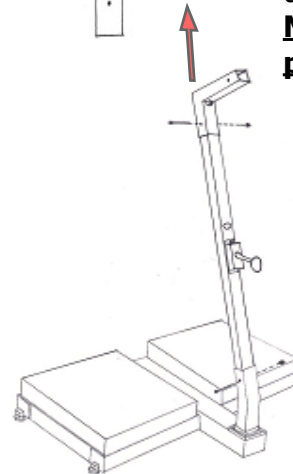

Carefully place it into the metal sleeve (E). Make sure it is fully down.

Secure the post with bolt (R), and the clear plastic stepped-washers.

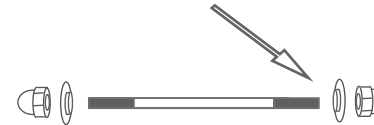

9. Attach the end hook (G) to the end of the cross-pole (M) with bolt(R) and plastic step washers.

Note the direction of the hook.

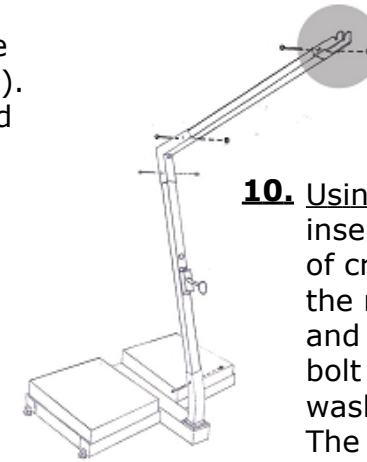
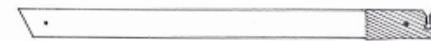

10. Using a suitable ladder, insert the angled end of cross pole (M) into the metal elbow (F) and secure with bolt (R) and plastic step washers. The cut-out faces up.

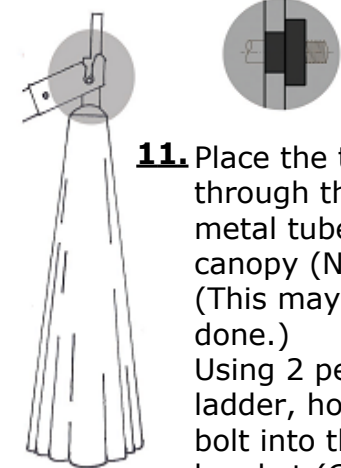

11. Place the top bolt (J) through the hole in the metal tube on the parasol canopy (N). (This may already be done.) Using 2 people and a step ladder, hook the canopy bolt into the cutout in bracket (G). Then put the larger (grey) plastic step washers and M10 self locking nut on either side.

Make sure the stepped washer sits in the circular part of the cut-out. See diagram. Then tighten the nuts using the spanners provided.

WINCH INSTRUCTIONS

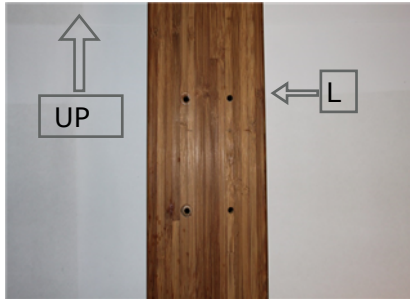

THE POST (L) HAS BEEN PRE-DRILLED



NEXT, INSERT THE WINCH MECHANISM, AND SECURE USING THE 4 SCREWS.



PLACE THE BOTTOM HALF OF THE OUTER SHELL, OVER THE SCREW HOLES AND SECURE USING THE LONG SCREWS. THE CUTOUT IS TO THE TOP.



PLACE THE TOP COVER ONTO THE WINCH, AND SECURE USING THE 2 SMALL SCREWS.



INSERT THE WIRE GUIDE INTO THE CUTOUT. (HOLE TO THE RIGHT).



YOUR WINCH SHOULD LOOK LIKE THIS.

Rope and wire assembly

Top rope. (beige)

1. Thread the top rope (from the top of the tube), over the pulley at A.
2. Run the rope through the looped part of the cleat at B.
3. Thread the rope through the hole in the Bamboo pull-handle (K).
4. Tie a simple knot on the end of the rope and pull the handle down. The knot should sit in the end recess.

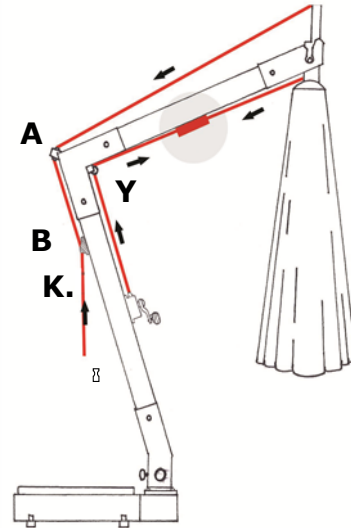

Winch wire

The wire should be loosely coiled in a bag.
Take the end of the wire, and feed it up through the lower pulley (Y)

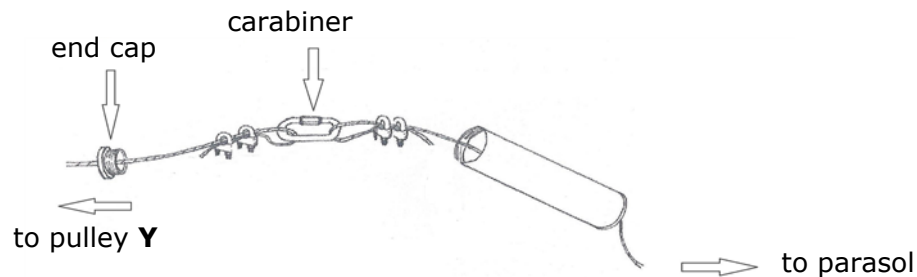

5. Unscrew the end cap (without wire) from the protector tube. Remove loose contents.
6. Thread the wire from pulley (Y) through the end cap.
7. Form a loop in the end of the wire and securely attach both of the 'Horseshoe' clamps (from inside the tube) onto the wire loop. (See diagram).
The loose end MUST be held securely by BOTH clamps
8. Link both the loops together with the locking 'Carabiner'.
This MUST be secured together using the locking nut, or damage/injury may occur.
9. Feed the clamps and carabiner into the tube and secure the end cap.

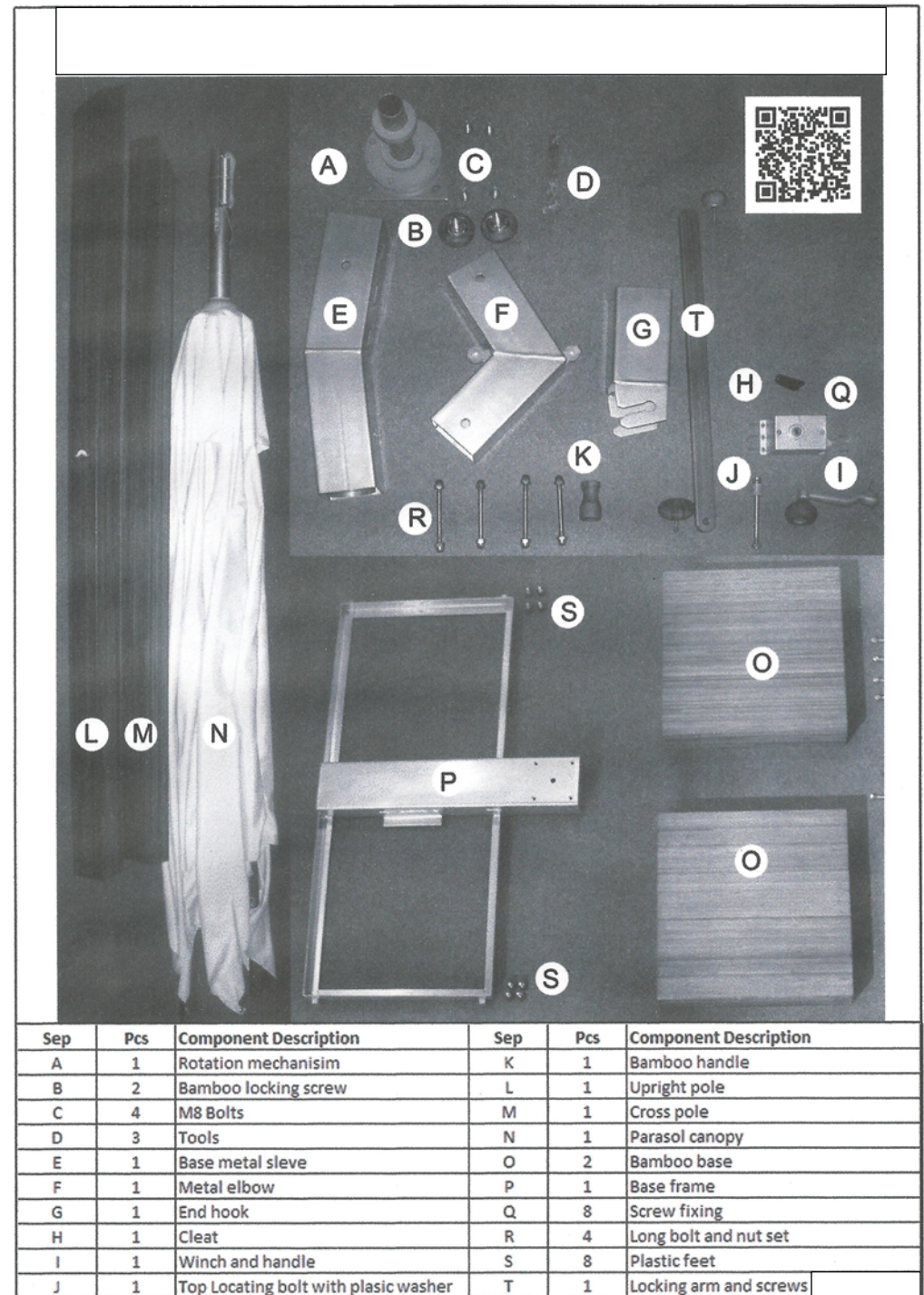

Sep	Pcs	Component Description	Sep	Pcs	Component Description
A	1	Rotation mechanism	K	1	Bamboo handle
B	2	Bamboo locking screw	L	1	Upright pole
C	4	M8 Bolts	M	1	Cross pole
D	3	Tools	N	1	Parasol canopy
E	1	Base metal sleeve	O	2	Bamboo base
F	1	Metal elbow	P	1	Base frame
G	1	End hook	Q	8	Screw fixing
H	1	Cleat	R	4	Long bolt and nut set
I	1	Winch and handle	S	8	Plastic feet
J	1	Top Locating bolt with plastic washer	T	1	Locking arm and screws

Please remove the winch handle when not in use, for safety, and also this part is not weather resistant.

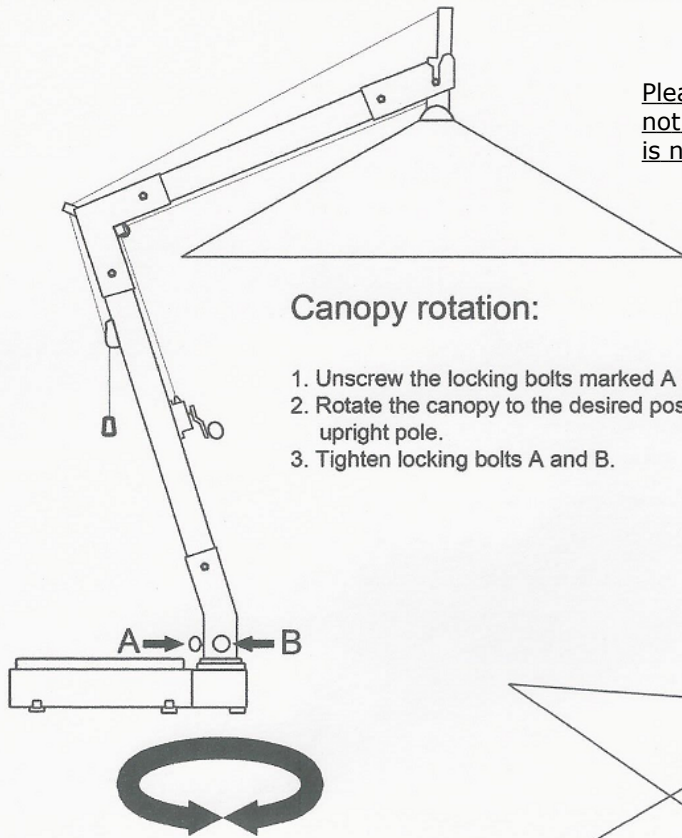

Canopy rotation:

1. Unscrew the locking bolts marked A and B, until loose.
2. Rotate the canopy to the desired position by twisting the upright pole.
3. Tighten locking bolts A and B.

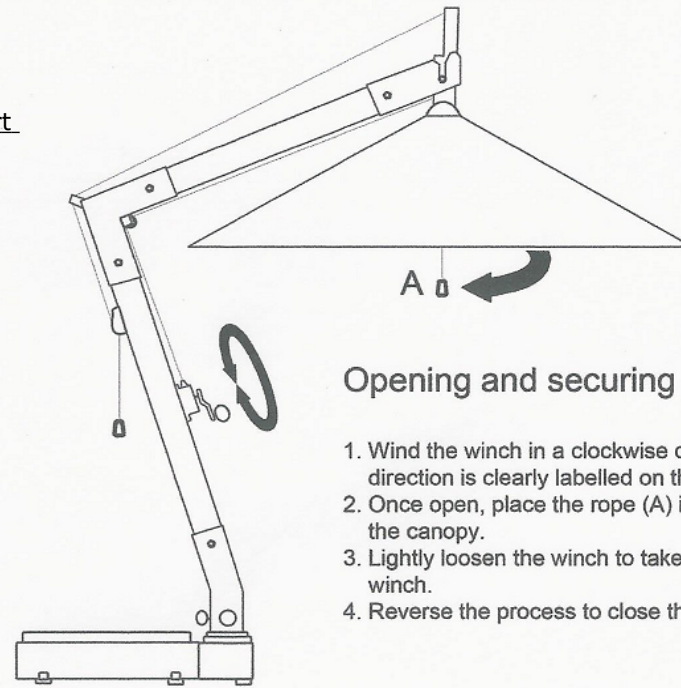

Opening and securing canopy:

1. Wind the winch in a clockwise direction to open. The direction is clearly labelled on the winch mechanism.
2. Once open, place the rope (A) in the cleat to secure the canopy.
3. Lightly loosen the winch to take the strain off the winch.
4. Reverse the process to close the canopy.

Locking and tilting the canopy:

1. Locking arm (A) can be used to secure the canopy in the open position. Make sure the clear, non slip plastic washers are on the threads between the arm and the parasol. The large handled locking bolt on the one side of the arm screws to the pole in either the higher or lower fixing point (D). The smaller handle on the opposite end screws to the canopy, on the arm closest to the pole. This fixing arm should always be secured when you are not using the tilt.
2. To tilt the canopy, unscrew the locking arm at the canopy and secure it to the pole, pushing it into the position point (C).
3. Pull the rope labelled B and simultaneously tilt the canopy by pushing the canopy arm nearest the pole downwards.
3. Lock the rope labelled B into the cleat to secure the canopy in the position desired.

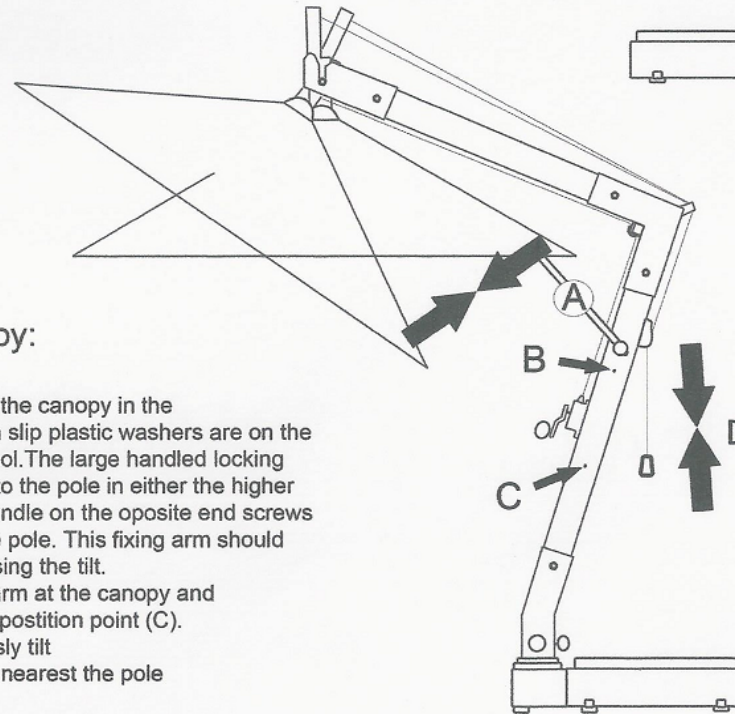

PLEASE NOTE:

Although our umbrellas have been tested to withstand use in very windy (test) conditions, we recommend collapsing your umbrella when the wind picks up above 25mph/40kph. Damage caused by stronger winds, is not covered by our warranty.

WHEN CANOPY IS CLOSED

Once the canopy is down, remove any folds from between the ribs to avoid chafing on the cover and use an umbrella tie to secure the canopy

IMPORTANT SAFETY NOTICE

PLEASE NOTE; NEVER HAVE THE CANOPY HANGING OVER THE BASES, (IMAGE ON LEFT), IF THE WIND SPEED IS ABOVE 10mph/15kph.

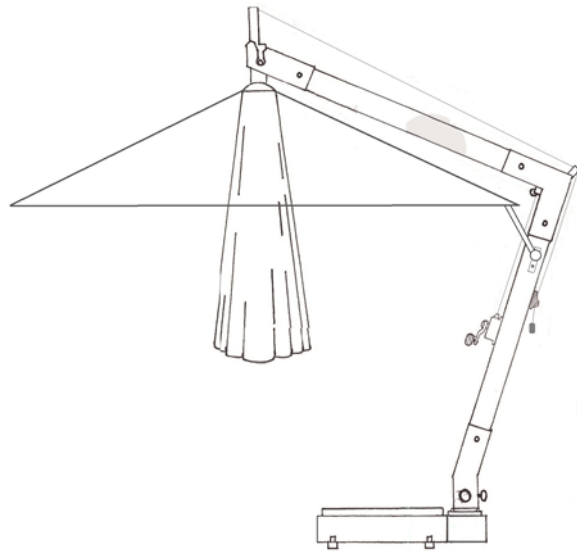

ALWAYS USE THE LOCKING ARM WHEN THE WIND GOES ABOVE 10mph/15kph AND DO NOT HAVE THE CANOPY TILTED IF THE WIND IS ABOVE 10mph/15kph.

